

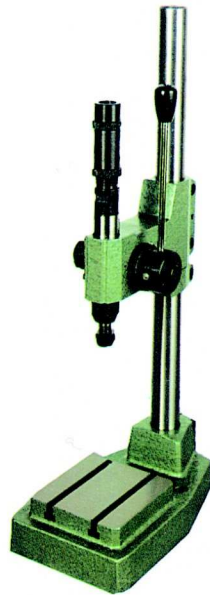

Durable Mecco
Model MC-11D Impact Press
Operation & Maintenance Instructions



Revised 05-16-2007



WARNINGS

1. Safety glasses must always be worn by the machine operator, as well as any co-workers, or any other persons in the area.
2. Never operate this press unless hands and foreign objects are clear of the pinch point area.
3. Never operate a machine in a pneumatic mode without approved dual hand controls that include anti-tie down features. Pneumatic operation requires the use of a filter-regulator-lubricator in the line. Flow controls must be used in the "U" series units.
4. Never remove any safety guards until the air is turned off and secured in the off position.
5. Never do any maintenance work on the press until the air is turned off and locked out with the air lines removed from the cylinder ports.
6. Never make any tooling or set up change until the air is turned off and locked out.
7. Never operate the press until the impact adjustment and the trip travel adjustment is correct. See operation manual for instructions.
8. Never operate the press with tooling (shank) of improper diameter. See machine specifications for proper shank size.
9. Never use hammer blows on any wrench to tighten any nuts on the machine. Hand tightening with a wrench is sufficient.
10. All moving parts must be regularly lubricated with a light grade machine oil. Periodic preventive maintenance scheduling should be established for cleaning, lubricating and inspection of all moving parts.



WARRANTY

All warranties of the products described herein, express or implied, including the warranties of merchantability and fitness for particular purpose are, except if contrary to state law, specifically excluded except the following: Mecco Marking will repair or replace any machine or machine part, which, within ninety (90) days after sale by Mecco Marking or its distributor is found to be defective in material or workmanship.

This is the sole warranty of Mecco Marking and shall extend to new equipment, repaired or replaced by Mecco Marking.

Mecco Marking, except if contrary to state law, shall not be liable for any injury or consequential, arising out of the use of, or the inability to use, the products described herein.



**TO VALIDATE YOUR WARRANTY
PLEASE RETURN THIS PAGE IMMEDIATELY TO:**

Fax: 1-630-766-0219

Or

**Durable Mecco
521 South County Line Road
Franklin Park, IL 60131**

Important Notice:

No person shall operate this equipment without first carefully studying and understanding the instruction manual. Contact Durable Mecco with any questions relating to the safe operation or limitations of this equipment.

The warranty, as presented in the manual, will become effective immediately upon return of this Disclaimer.

Model No. _____

Serial No. _____

Company _____

Address _____

Signed _____

Title _____

Phone _____

E-mail _____

Date _____



Model MC-11D Impact Press

Operation & Maintenance Instructions

Principle of Operation

The press contains a large spring that is compressed during energy section travel. When release point is reached, the compressed energy is released causing the internal hammer to deliver the powerful impact.

Step 1

Energy section advances toward workpiece by gear rack and pinion, powered by double-acting pneumatic cylinder (pneumatic units) or by operator pulling lever (manual units).

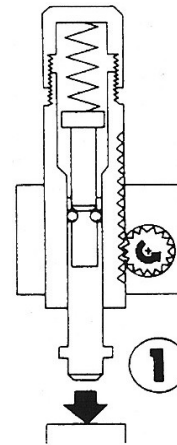

Step 2

After workpiece is contacted, stroke continues. The workpiece is held in place by the pressure from the energy section. The Impact Spring is compression builds as the press continues to maintain contact with the workpiece.

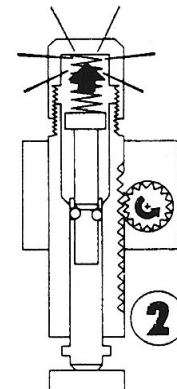

Step 3

When ball bearings reach release point, the powerful impact is released. The Impact Spring delivers force to the hammer, which in turn strikes the plunger (tool holder).

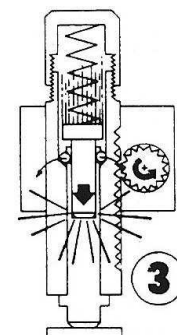

The result is a strong impact from a small press.

**Delivery:**

Units are shipped in heavy-duty containers to prevent damage in shipment. Should any damage be found, claims should be made immediately against the freight carrier.

Installation:

1. The machines should be cleaned and all anti-rust lubrication should be removed, with special care given to removing this film from the COLUMN (Part #37).
2. All machines are designed with bolt-down holes in the TABLE CASTING (Part #42). The machine should be bolted securely to a rigid bench that is level and located in a safe location.

Impact Adjustment:

1. The press is rated at the maximum force possible.
2. Machines are shipped with three (2) different gauge IMPACT SPRINGS (Part #10).
3. Force can be adjusted by adjusting the IMPACT ADJUST CAP (Part #12)
4. Force can be adjusted by selecting a heavier or lighter gauge IMPACT SPRING (Part #10)
5. When the proper impact force is determined, the IMPACT ADJUST LOCK NUT (Part #15) should be tightened to prevent changes due to vibration or tampering.

NOTE

IMPACT FORCE IS **NOT** ADJUSTED BY CHANGING THE THROAT OPENING (THE DISTANCE TO THE WORKPIECE)

NOTE

IMPACT FORCE IS **NOT** ADJUSTED BY CHANGING THE AIR PRESSURE TO THE MACHINE CYLINDER



Tooling Installation:

CAUTION

ALL AIR SUPPLY TO THE MACHINE MUST BE SECURED IN THE OFF POSITION PRIOR TO TOOLING INSTALLATION.

1. This press uses a collet arrangement for retaining the tooling in the machine. For proper retention in the collet, the shank size is critical. The following shank size must be used:
6.0mm dia. X 27mm
2. The COLLET NUT (Part #23) must be loosened and the tool shank inserted through the COLLET (Part #22) until it is bottomed into the PLUNGER (Part #19).
3. Tighten the COLLET NUT (Part #23) securely to prevent tool rotation.

NOTE

DO NOT USE HAMMER BLOWS AGAINST THE WRENCH TO TIGHTEN.

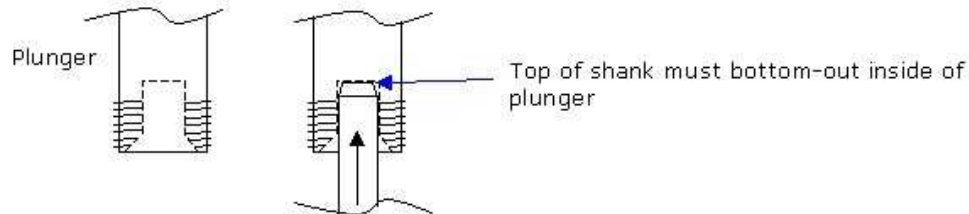

Collet, Collet Nut, Trip Travel Adjust Nut, Trip Travel Lock Nut And Trip Travel Lock Washer are not shown for clarity

**Standard plunger and shank shown. Some systems are specially modified per application.



Operating Height Adjustment:

1. With work piece in place on the machine table, or nested in a suitable fixture, lower the tooling toward the work piece by loosening the CLAMP BOLTS (Part #44) on the upper casting.
2. Secure CLAMP BOLTS (Part #44) before operating the machine.

a	Maximum Total Travel	35.0mm
b	Compression required to realize impact	11.5mm
c	Maximum distance between tool and work piece in rest position (Optimal distance is 6mm or less)	23.5mm

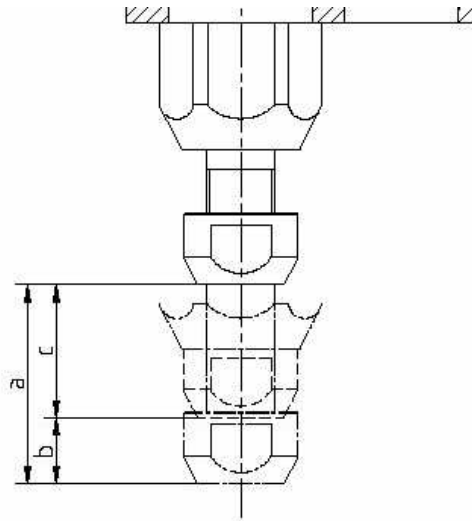

NOTE

THE DISTANCE FROM THE TOOLING TO THE WORKPIECE, WITH MACHINE AT REST, SHOULD BE KEPT TO A MINIMUM (1/4" OR LESS).

Lever Return Travel Adjustment:

1. The lever tension can be adjusted by loosening the two (2) ALLEN SCREWS (Part #41) located in the sides of the LEVER RETURN SPRING HOUSING (Part #33). With these screws loose, the LEVER SPRING ADJUST BOLT (Part #40) will be free to adjust to the desired tension.



Maintenance:

CAUTION

ALL AIR SUPPLY MUST BE SECURED IN THE OFF POSITION PRIOR TO MAINTENANCE OR TOOLING CHANGE.

1. Depending on the usage and operating conditions, the MECCO machines should be regularly lubricated at all wear points. Periodically, the machine should be disassembled for cleaning, inspected for worn parts and lubricated completely.

Use a lightweight machine oil like 3-In-One™ to lubricate machine through the oil fittings (Part #69). Apply general-purpose lithium grease to the Piston Rod (Part #45) and the Lower Tube (Part #2).

2. Care must be given to the pneumatic lubricator oil level to assure proper lubrication of the pneumatic cylinder.



Optional Pneumatic Add-On Air Installation & Maintenance:

WARNING:

BEFORE INSTALLING THE ADD-ON AIR CYLINDER TO THE PRESS, REMOVE THE MANUAL OPERATING LEVER (PART #35) FROM THE MACHINE.

1. The standard pneumatic cylinder available is a single acting cylinder, usually requiring a three-way pneumatic valve. For safe press operation, only DUAL HAND CONTROLS with ANTI-TIEDOWN features should be used and a Filter-Regulator-Lubricator should always be used in every installation.

CAUTION:

DO NOT USE A FOOT VALVE.

2. Install the standard AIR CYLINDER and MOUNTING BRACKET on the press COLUMN (Part #37). The AIR CYLINDER should be positioned on the COLUMN (Part #37) with the CYLINDER PISTON ROD centered and touching against the IMPACT ADJUST CAP (Part #12).
3. Tighten the CYLINDER MOUNTING BRACKET securely to the COLUMN (Part #37) before operating the air.
4. With the MANUAL-OPERATING HANDLE (Part #35) removed, connect airline to the cylinder and turn the airline regulator to a low setting. Operate the pneumatic press controls to signal the press to travel down against the work piece. With the regulator set at a low-pressure setting, the press should not impact.
5. Increase the line pressure at the regulator until the machine impacts against the work piece. The line pressure to the machine should not exceed the pressure required to trigger the impact.
6. Any change made in the impact setting will require the line pressure to be adjusted.

Optional Pneumatic Add-On Air Maintenance:

Periodically check the pneumatic lubricator oil level to assure proper lubrication of the pneumatic cylinder.



Parts ordering - Information required:

1. Please furnish part number and part name.
2. Please furnish machine model number.
3. Please furnish serial number.
4. Please furnish quantity desired.

For all information and/or correspondence concerning this machine, please state type and serial number.

Serial Number: _____

Date: _____

Signature: _____



Spare Parts List Model MC-11D

Mark	Part #	Old Part #	Description 1	Description 2
1	20-101001	20-MC1101	Main Casting	HOUSING BLOCK
2	20-101102	20-MC1102	Lower Tube	RACK
3	20-101103	20-MC1103	Sleeve Return Spring	SLIDING-BUSH SPRING
4	20-101104	20-MC1104	Bearing Sleeve	SLIDING-BUSH
5	20-101105	20-MC1105	Tube Guide	GUIDE SLEEVE
6	20-101106	20-MC1106	Ball Bearings	BALLS Ø2,5
7	20-101107	20-MC1107	Tube Guide Return Spring	GUIDE-SLEEVE SPRING
8	20-101108	20-MC1108	Upper Tube	COUPLING SLEEVE
9	20-101109	20-MC1109	Hammer	HAMMER
10	20-101110	20-MC1110	Impact Spring-2.3mm Wire Diameter	PENETRATION SPRING
10	20-101110-2.5	20-MC1110	Impact Spring-2.5mm Wire Diameter	PENETRATION SPRING
12	20-101112	20-MC1112	Impact Adjust Nut	CAP
19	20-101119	20-MC1119	Plunger	TOOL-HOLDER
20	20-101120	20-MC1120	Plunger Key	TOOL-HOLDER KEY
21	20-101121	20-MC1121	Plunger Retaining Nut	RETAINING NUT
22	20-101122	20-MC1122	Collet	COLLET
23	20-101123	20-MC1123	Collet Nut	COLLET NUT
24	20-101024	20-MC1124	Lower Tube Key	RACK KEY
25	20-101025	20-MC1125	Lower Tube Key Nut	KEY NUT M4
26	20-101026	20-MC1126(P?)	Pinion	PINION
27	20-101027	20-MC1127D	Pin Guide	PIN GUIDE
28	20-101028	20-MC1128	Pinion Shaft Bush Screw	ALLEN SCREW M5X10
29	20-101029	20-MC1129	Lever Housing	LEVER COUPLING
30	20-101030	20-MC1130	Pinion Drive Pin	ELASTIC BOLT
31	20-101031	20-MC1131	Lever Housing	RETAINING SCREW
32	20-101032	20-MC1132	Lever Return Spring	LEVER SPRING
33	20-101033	20-MC1133	Pinion Shaft Bearing	SPRING HOUSING
34	20-MC1134	20-MC1134	Pinion Shaft Bearing Bolt	
35	20-101035	20-MC1135	Lever Handle	DRIVING LEVER
36	20-101036	20-MC1136	Lever Handle Ball	ROUND KNOB BALL



37	20-101037	20-MC1137	Column	COLUMN
37	n/a	20-MC1137 *	Column (EXTRA LONG)	
38	20-101038	20-MC1138D	Ball Bearing	BALLS Ø5
39	20-101039	20-MC1139D	Spring	LOCKING SPRING
40	20-101040	20-MC1140	Lever Return Spring Adj Bolt	TIGHTENING PLAY
41	20-101041	20-MC1141	Pinion Shaft Bearing Bolt	CONICAL STUD M6X10
42	20-101042	20-MC1142	Table	TABLE
43	20-101043	20-MC1143	Collar	RING
44	20-101044	20-MC1144	Clamp Bolt	ALLEN SCREW M6X20
63	20-101163	20-MC1163	Upper Tube Lock Nut	CAP LOCKNUT
65	20-101165	20-MC1165	Shock Absorber	STOP RING
69	20-101069	20-MC1169	Oil Fitting	BALL GREASER D6
76	20-101076	20-MC1176D	Pin	ELASTIC BOLT D4X15
77	20-101077	20-MC1177D	Stud	CYLINDRICAL STUD M6X10
78	20-101078	20-MC1178D	Washer	LEVER COUPLING WASHER
81	20-101081	20-MC1181	Table Set Screw	CONICAL STUD M6X20
88	20-101088	20-MC1188	Main Casting Bolt	CYLINDRICAL STUD M6X15



MC-11D

